

BUTLER

SPECIALTY COMPANY

EST. 1930

Assembly Instructions

6311488

6311497

6311498

Sideboard

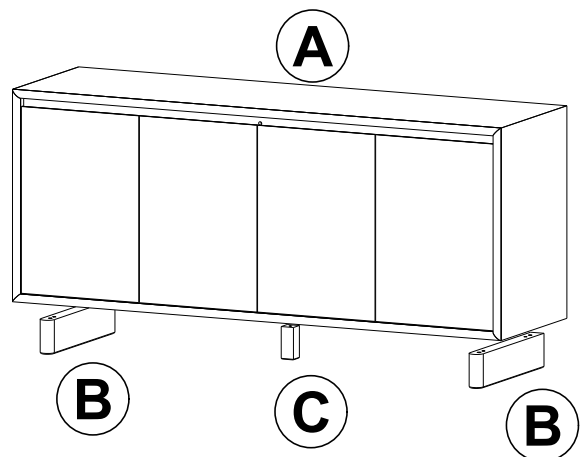
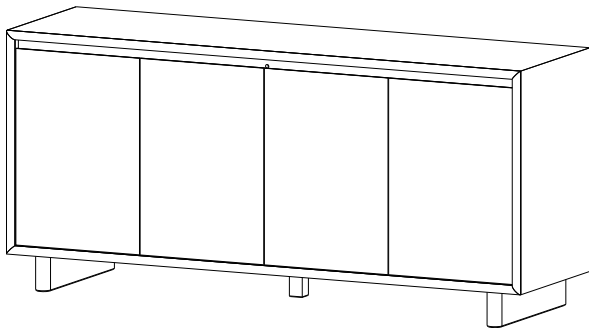

ITEM	DESCRIPTION	QUANTITY
A	Sideboard	1 Pc
B	Leg	2 Pcs
C	Center Leg	1Pc
D	JCBC M6 x 100 mm	4 Pcs
E	Dowel 10 x 30 mm	4 Pcs
F	Lock Washer M6 x 13mm	4 Pcs
G	Flat Washer M6 x 16 mm	4 Pcs
H	Allen Key 4	1 Pc

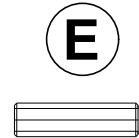
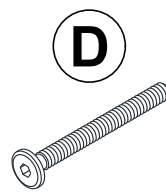

STEP 1



STEP 2

Attach Legs (B) to Top Table (A) using Bolt M6 x 100 mm (D), Lock Washer M6x13 mm (F), Flat Washer M6x16 mm (G), Allen Key 4 (H) clockwise to tighten as shown below.

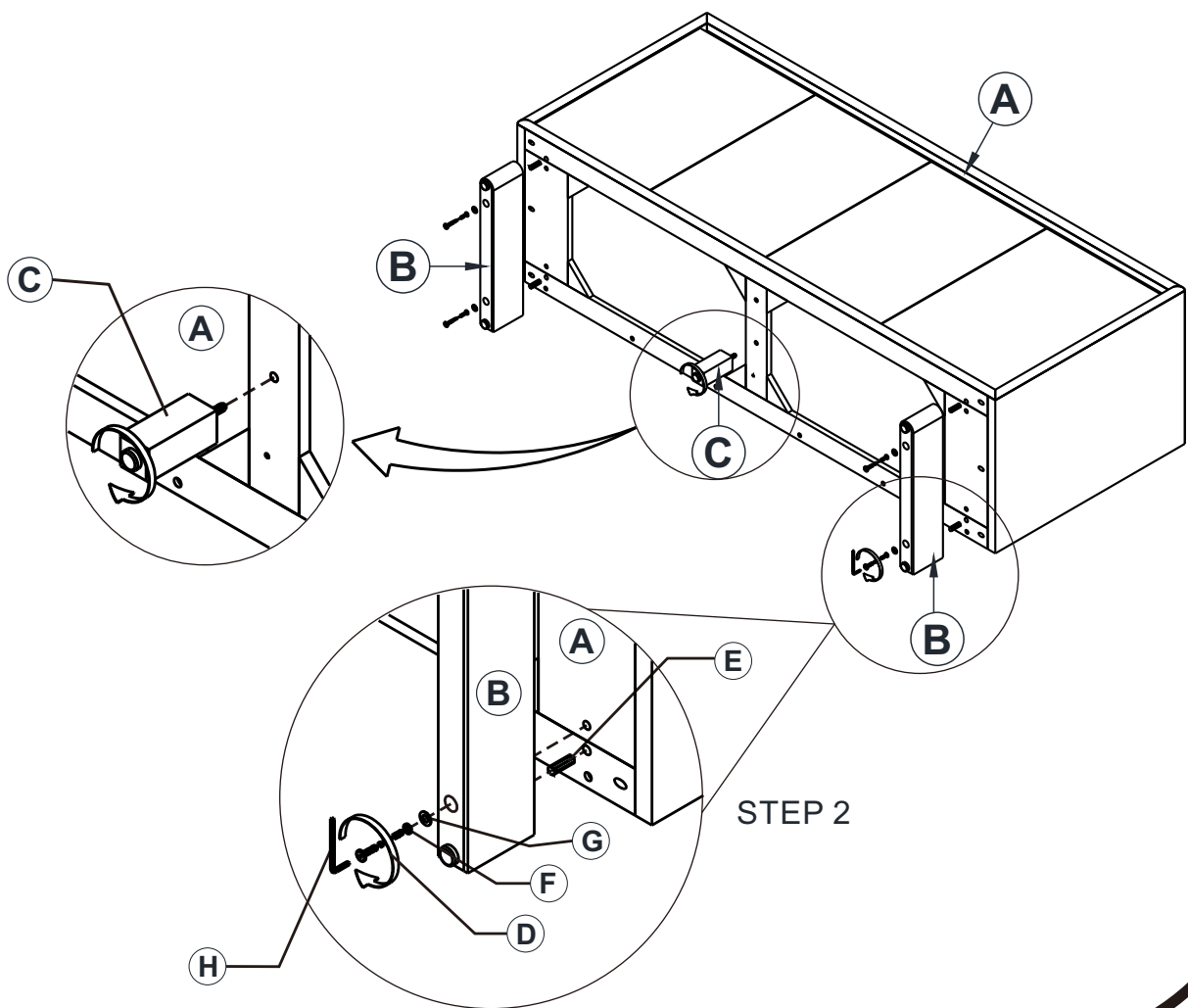

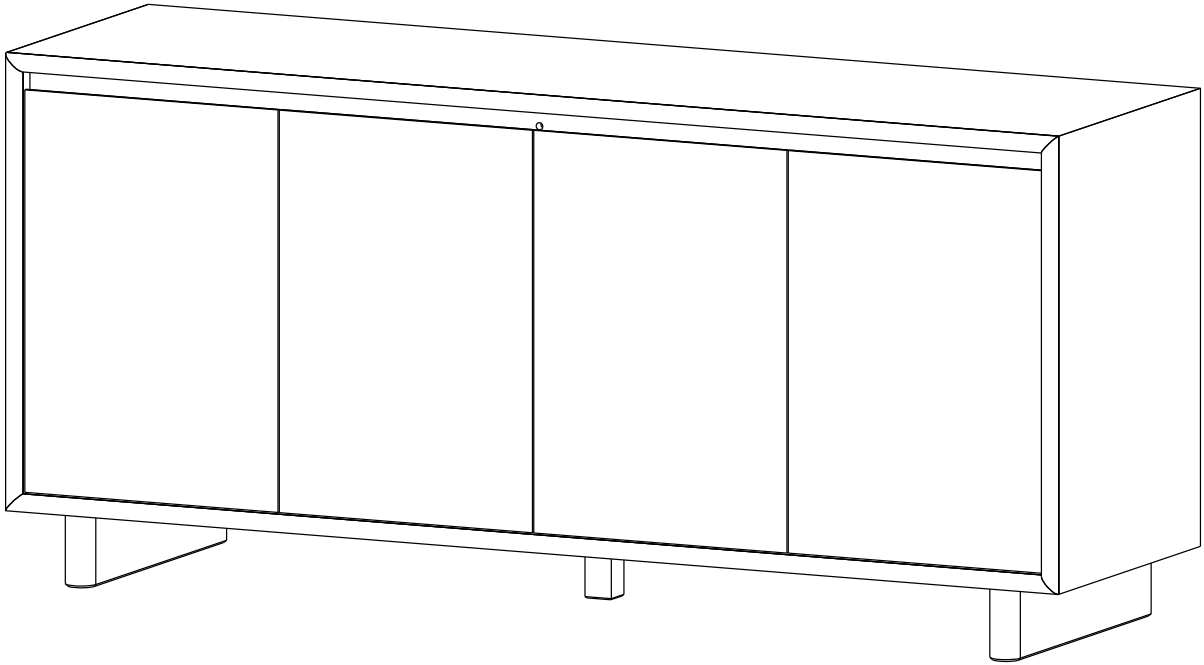

Congratulations

Assembly complete, Your Sideboard is ready to use.

(*) Caution : DO NOT OVERTIGHTEN

In any correspondence regarding this product, please include the complete Butler identification number located on the underside of the product.

We hope this product will be a useful and decorative addition to your home for years to come.

Copyright© Butler Specialty Company, 09 / 25